

WILA Precision Tooling

Discover the WILA Safety-Click Advantage

WILA punches are fitted with Safety-Click buttons that provide precise vertical mounting, and self-seating when used in combination with a WILA Hydraulic Ram Clamping system. The Safety-Click system and hydraulic clamping also enable exceptionally fast tool changes.

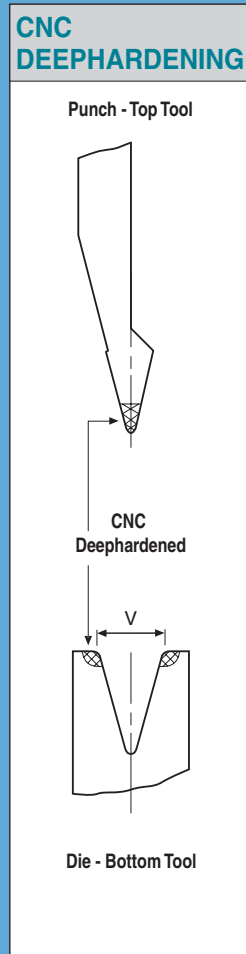
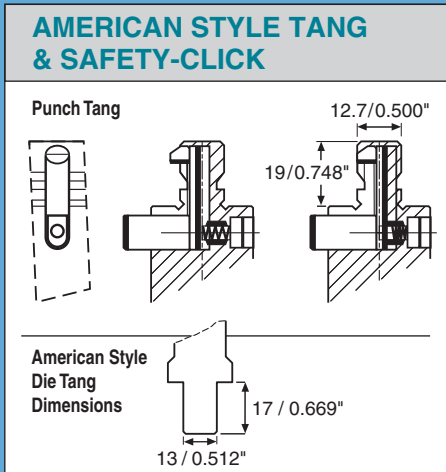

- **Safety-Click Buttons for Quick Vertical Tool Exchange**

Both WILA American Style and New Standard tooling come with the patented Safety-Click button system for quick vertical exchange.

- **Tools Automatically Self-Seat when used with WILA Clamping Systems**

Both American and New Standard tooling seats and aligns automatically when used with a WILA Clamping system, eliminating the need to bring down the ram to seat the tools.

- **CNC-Deephardening Provides Outstanding Tool Life**

Both American and New Standard tooling are manufactured from a special Chrome-Molybdenum alloy with extremely high tensile strength and load bearing capacity. To provide outstanding tool life and wear resistance, all WILA tools are CNC-Deephardened at the wear points to Rockwell 60C to a depth of 3mm / .118".

- **Precision Ground to the Highest Accuracies**

WILA New Standard tooling is precision ground to +/- 0.0004" / 0.01mm and WILA American Style is precision ground to +/- 0.0008" / .02mm.

- **Sectionalized for Versatility and Easy Operator Handling**

All WILA tools are manufactured in lengths of 515mm / 20.276" or smaller sections for easy handling by the operator. Tool sections can be combined to form any desired length from 20mm / 0.787" up to machine length in 5mm / 0.2" increments.

