

Hemming Dies

Hemming Dies

These combinations are used for hemming on a two-stroke operation.

- HM-1 is used to hem 18 gauge or lighter.
- HM-2 is capable of both air-bending and hemming light gauge material.
- HM-3 is for hemming material heavier than 18 gauge.
- HM-4 can be customized to suit individual applications.

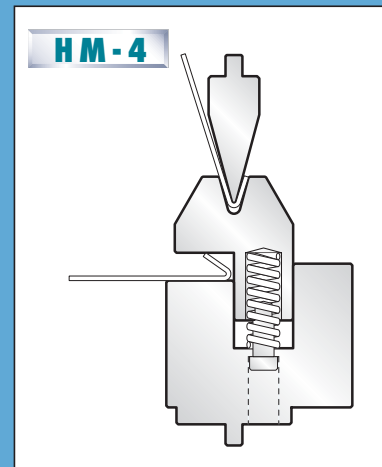
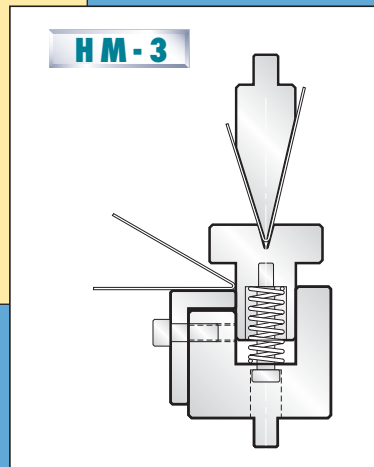
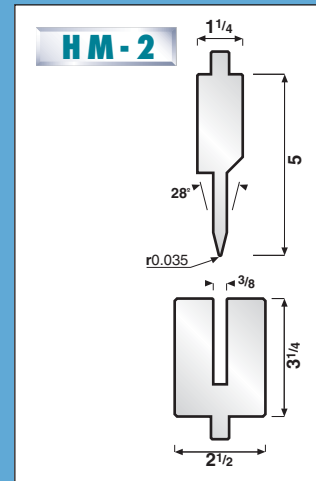
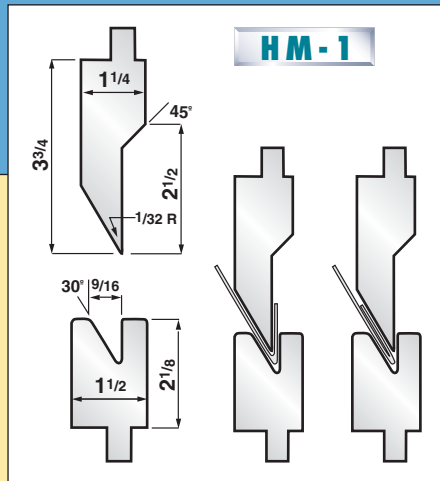

Ram Adaptors

Ram Adaptors

Ram adaptors may be necessary to fill up die space if ram adjustment is insufficient, or to suit conditions for box forming.

The three styles shown are in 3 3/4" but are available in all heights. They have safety tangs, and are manufactured from 4150 material.

