

Gooseneck Punches & Dies

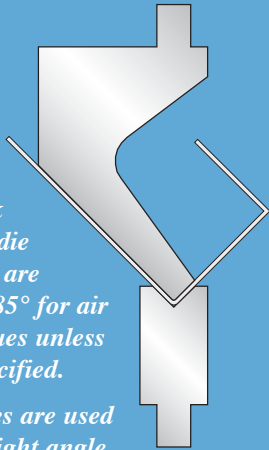
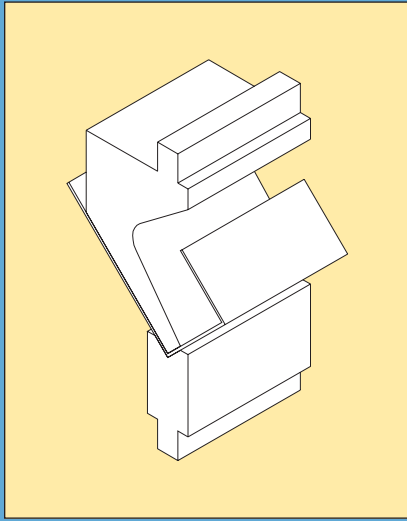

All gooseneck punches and die combinations are machined at 85° for air bend techniques unless otherwise specified.

These punches are used for forming right angle bends, channels, or other special bends where a straight 90° punch would interfere.

GN #7, 8 and 9 punches are cut back further beyond the centerline for a greater flange.

