

85°-90° Forming Punches & Dies

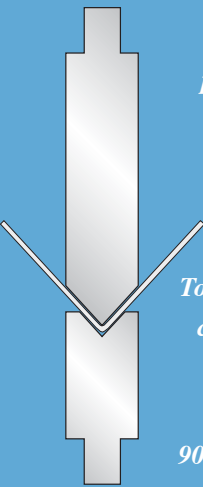

These 85° punch and die combinations are used for air bending techniques. To produce sharp, close-tolerance bends in light gauges, 90° punch and die combinations must be specified.

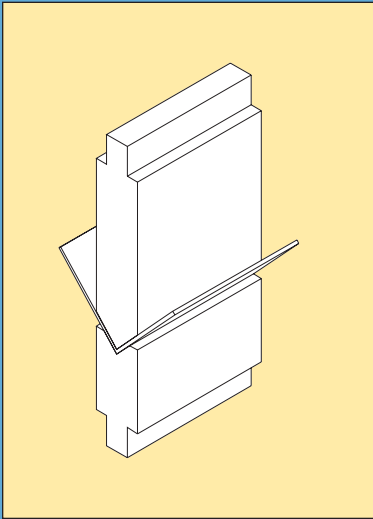