

to Your Specifications

SPECIAL CURLING PUNCH

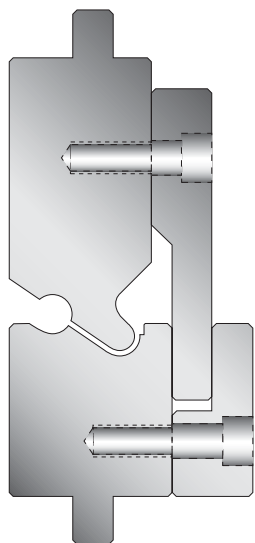

SPECIAL DOOR FRAME

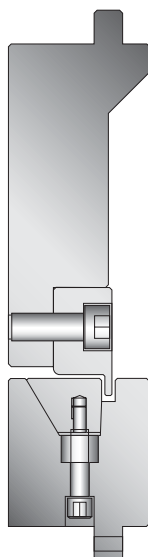

4-WAY 3 – HVAC

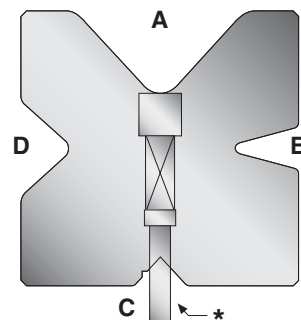

A = 2.000" @ 85°
 B = 0.500" @ 30°
 C = 0.625" @ 85°
 with notch for 1/4" flange
 D = 1.125" @ 85°

* Disappearing Spring Pins
 for locating sheet metal –
 3 total

SPECIAL MULTIPLE HIT FORMING

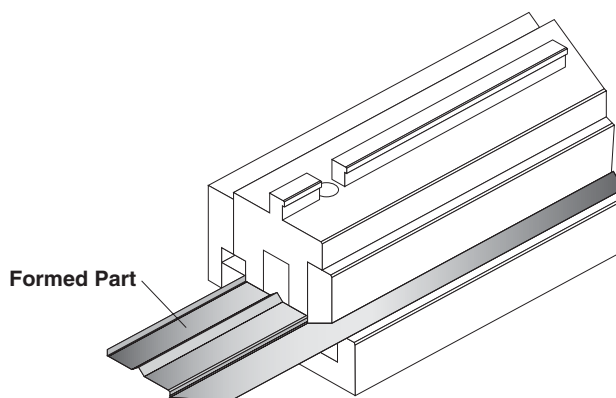
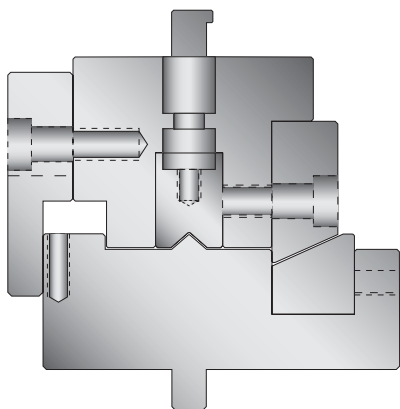

SPECIAL RADIUS BENDING

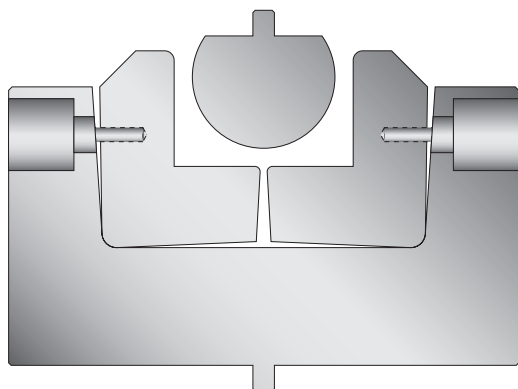

URETHANE PROTECTIVE DIE FILM

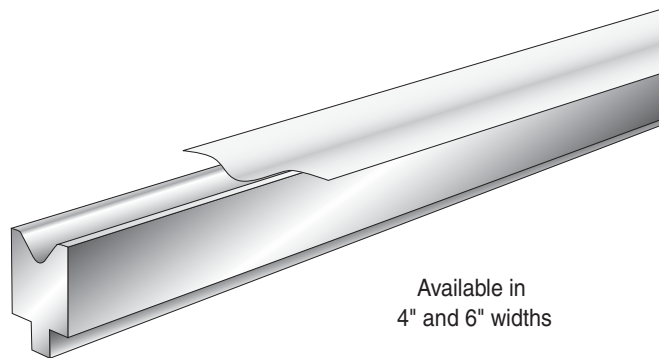

Available in
 4" and 6" widths